

MECHANICAL:

1. HOUSING: POLYCARBONATE, UL94V-2.
PLATED WITH GOLD FLASH
2. CONTACT: PHOSPHOR BRONZE.
3. HOUSING COLOR: TRANSPARENCE.
4. OPERATION TEMPERATURE: -40°C TO 80°C.
5. CABLE TO TENSILE STRENGTH: 7.7KGS
4. UNSPECIFIED TOLERANCE: .XX ±0.1[0.004]

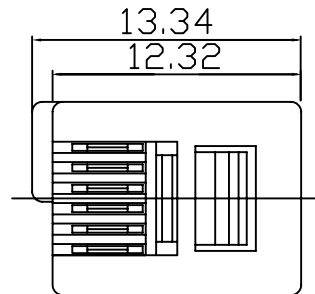
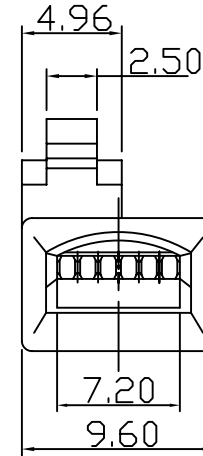
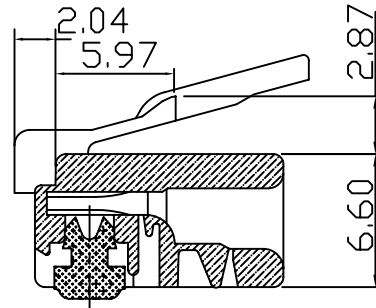
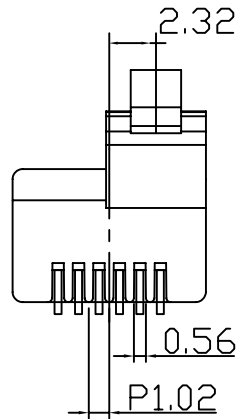
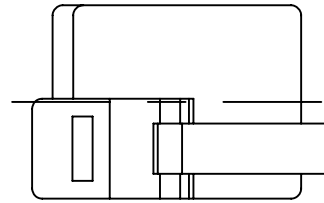

RoHS Compliant

		<small>THE INFORMATION AGE</small>	
<small>XMULTIPLE ASIA 4F, No. 347, Yang Guang St., Neihu, Taipei, Taiwan 11475</small>		<small>XMULTIPLE USA 1420 Los Angeles Ave., Suite G, Simi Valley, CA 93065</small>	
THIS DRAWING IS A CONTROLLED DOCUMENT.		<small>G/NO: X11Z-66U-002</small>	
<small>TITLE:</small> RJ11, 6P,6C, Plug For Round cable		<small>DRAWN:</small> TOM	
<small>PART NO:</small> X11Z-66U-002		<small>CHKD:</small> JEFF	
		<small>UNIT</small> mm[inch]	<small>SHEET</small> 1 of 1
		<small>REV</small> 01	<small>DATE:</small> Nov.28,07