

3L P/N : SMTDR0904HC-100M

YOUR REF.:

1.MECHANICAL DIMENSIONS (外形尺寸): DRAW NO.: SMTDR0904HC

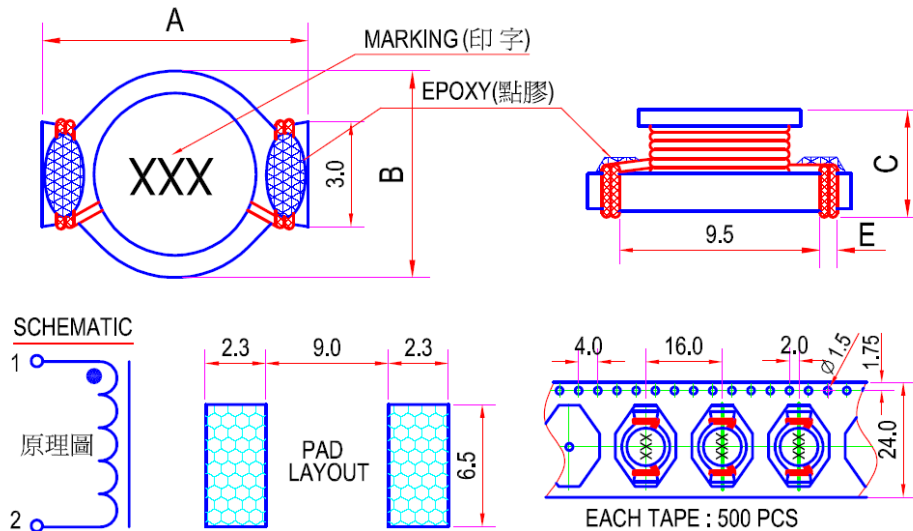

Item項目	Spec.(規格mm)	Typ.(參考值)	Item項目	Spec.(規格mm)	Typ.(參考值)
A	13.2 MAX	12.85	F		
B	9.9 MAX	9.68	G		
C	6.0 MAX	5.28	H		
D			I		
E	0.74 REF	0.75	J		

2. NOTES (備注, 包括印字及起始同相端等特別要求):

2.1 Marking (印字): "100"

CUSTOMER APPROVED (客戶確認)

APPROVED(確認)

CHECKED(檢查)

DRAWN(制圖)

工程部
2011/10/27
胡漢軍

工程部
2011/10/27
張小紅

工程部
2011/10/27
劉二娟

3L P/N : SMTDR0904HC-100M

YOUR REF.:

3. ELECTRICAL CHARACTERISTICS (電特性要求) :

Item (項目)	Specifications (規格)	Typ.(參考值)	Test equipments (測試設備) :
L	10uH +- 20%	9.67uH	HP4284A PRECISION LCR METER
L Load	(+3.3A) L Drop 30% REF	9.42uH	HP4284A WITH HP42841A CURRENT SOURCE
Test Freq.	@100kHz 0.25V		HP4284A PRECISION LCR METER
DCR	28mΩ Max	25mΩ	CHENHWA 502 OHM METER
I sat	3.3A		HP4284A WITH HP42841A CURRENT SOURCE
I rms.	4.3A		HP4284A WITH HP42841A CURRENT SOURCE
Turns	15.5TsX2 Ref(雙線並繞)		
Ope.Temp.	-40°C TO 85°C		HC-D3M TEMP. & HUMIDITY CHAMBER

ELECTRICAL NOTES (電特性備注欄) :

APPROVED(確認)	CHECKED(檢查)	DRAWN(制圖)
		